



## Modular Data Center Solution



# Contents

**Company Introduction**-----1

**Modular Data Center Solution**-----2

Micro Modular Data Center-----8

Medium Modular Data Center-----9

Large Modular Data Center-----12

**Successful Applications**-----14



Rail transit



Data center



Communication  
base station



Industry



EV charger



Medical



Finance



Government



Ground pv  
power station



Roof pv  
power station

# Kehua Tech Power Solution Specialist

Stock No.: 002335



KEHUA Group, as the leading power solution provider in mainland China, was founded in 1988. On Jan.13th, 2010, Kehua officially went public and was listed on Shenzhen Stock Exchange, which represented another milestone in company history.

Till now Kehua owns 8 subsidiaries, 5 production bases, 3 R&D centers, 1 EMC test center and a UL witness Test Data Program. There are more than 50 offices in domestic market, totally over 3000 employees in this team, including over 300 engineers and 3 national experts in power industry.

With more than 28 years experience in power market, Kehua's products have been installed in more than 80 countries and regions. Products match the certificates of CE, SAA, TUV and others for different market request.

The data center solutions we supply include: Micro data center, Medium data center and Large data center.



## The future blueprint for data center

- With the development of information technology, the traditional data center construction, operation and maintenance obviously can't meet the needs of business expansion. In this situation, the modular data center becomes the new trend.
- There are three modular data center solutions in Kehua to meet different customer demand:

Micro Modular Data Center



Medium Modular Data Center



Large Modular Data Center

- Modular data center is comprised of system module with different function and capacity, the customized solution is available as per our clients' request.

## Modular Data Center

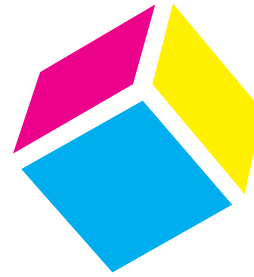

# 7 Advantages Give You More Benefits

Kehua green modular data center is launched based on the security of physical infrastructure. Our strength is to help the clients to build up intelligent and green data centers. What we can do is to make investment budget, system planning, system design, power distribution, cooling system, and monitor integration for the business partners. We aim to make everything easy for end-users; our roles are not only systems designer and equipment manufacturer, but also the service provider.

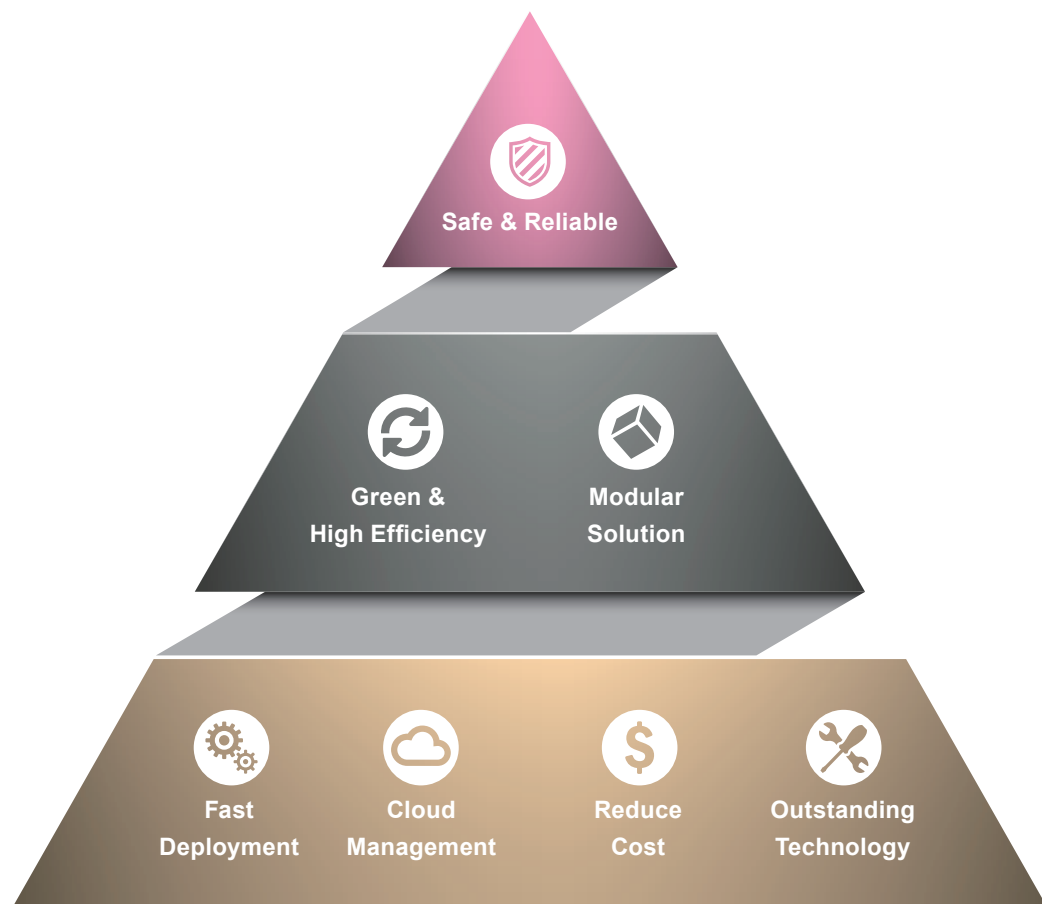



## Safe & Reliable

- High-end technology and good quality ensures system security and availability
- Multi- design in device, component and system
- High reliability design according to IT infrastructure environment and facilities
- Advanced and practical technology, equipment and environment-friendly materials to ensure safety and comfort
- Digital and intelligent network enhances the safe and reliable operation and maintenance



## Green & High Efficiency

Micro power distribution system, micro modular cooling system and micro module rack system can make 20% to 30% energy-saving. Through the CFD room assessment of thermal simulation and optimization of indoor airflow, the modular data center improves the ROI (return on investment).

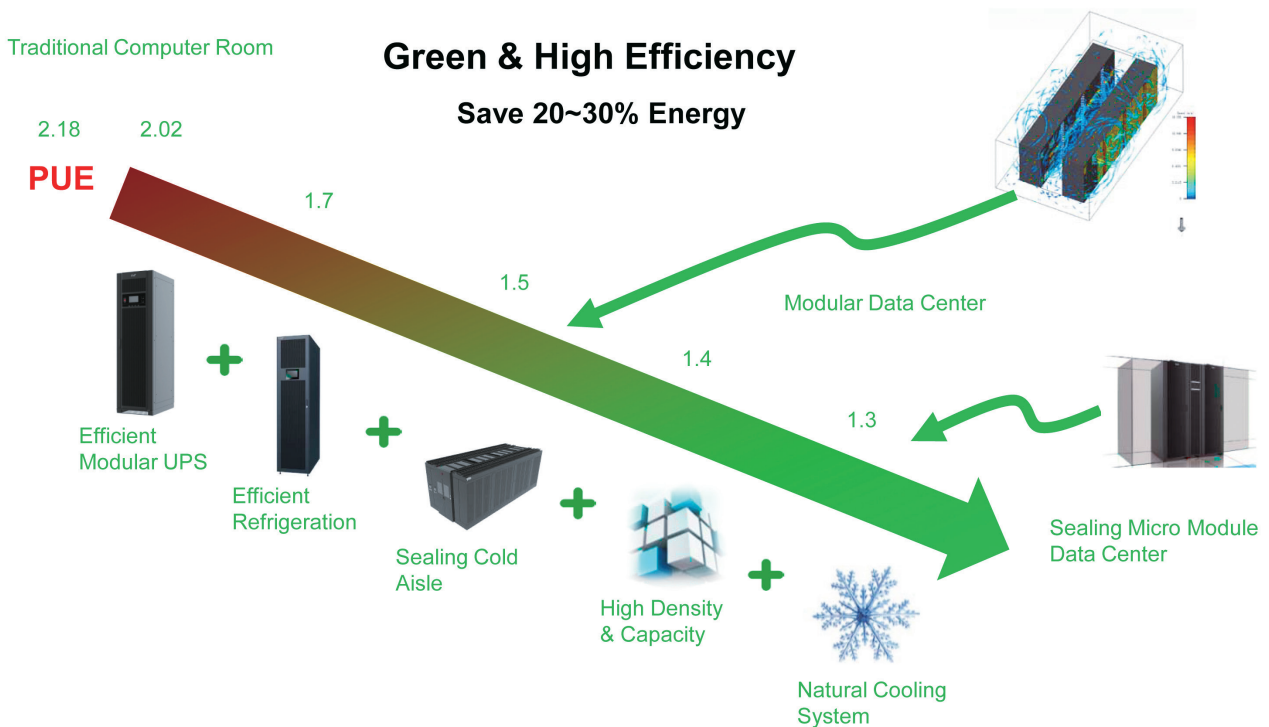



## Modular Solution

Modular unit makes modular solution simple and integrated.

- All-in-one: UPS + Air conditioner + Power Distribution + Monitoring + Battery, etc.
- Easy Installation: Building your blocks according to customers' demand.
- Fast Deployment
- Intelligent monitoring system management
- Shorten the line transmission distance.





## Fast Deployment

The client only needs building blocks according to the customer's IT requirements and architectural space. The future power expansion can be continued without interference. The goal is to optimize the delivery time, the maximum construction period can be saved more than 50%.

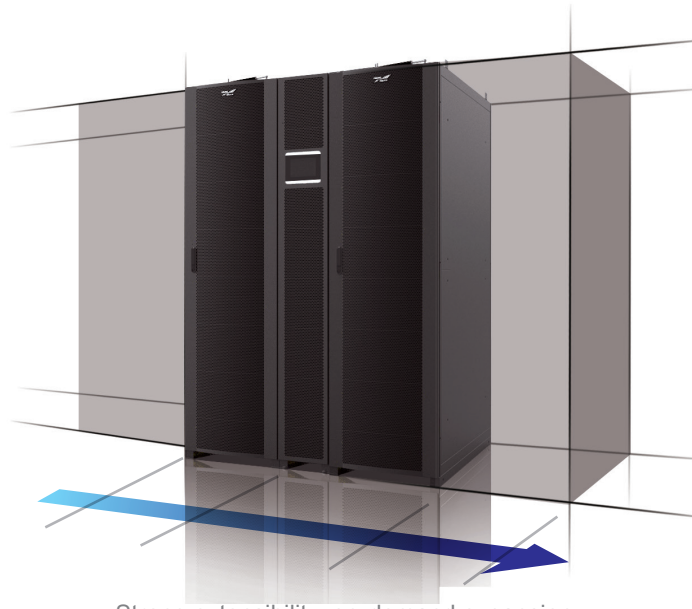

Strong extensibility, on-demand expansion



## Cloud Management

- Real-time online monitoring and alarm system to motivation, environment, security, fire control system etc.
- Unattended, rapid fault location and problem quick handling by multiple sites remote monitor management - 7 days x 24hours
- Multiple management functions - Settings, Alarm, Security, Energy efficiency, Record & Report management







## Reduce Cost

Standard modular data center, the end-to-end service, your clients and you will be happy to know:

- Saving considerable design fee
- Shortening your capital takes up cycle
- Improving operational efficiency
- Reducing operation cost
- Shortening payback period
- Optimizing your customer funds utilization

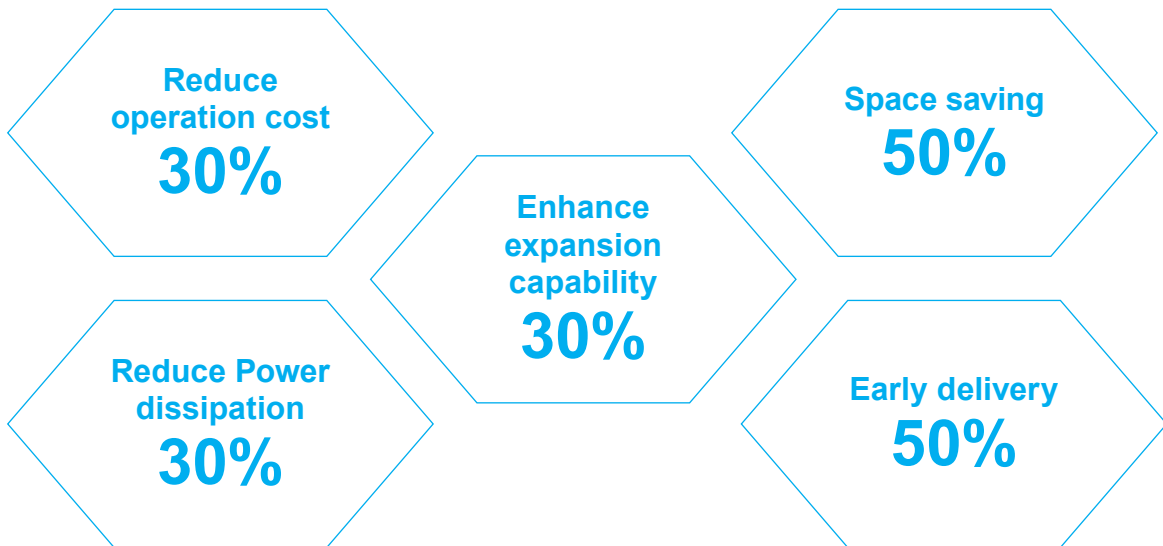

## Outstanding Technology

- High procedures, high specifications, high standard requirement
- The system power expansion is supported with sufficient bearing capacity
- High reliable standard server rack, installing each equipment according to the cold aisle and hot aisle
- Flexible air exhausting according to different airflow and data center ratings

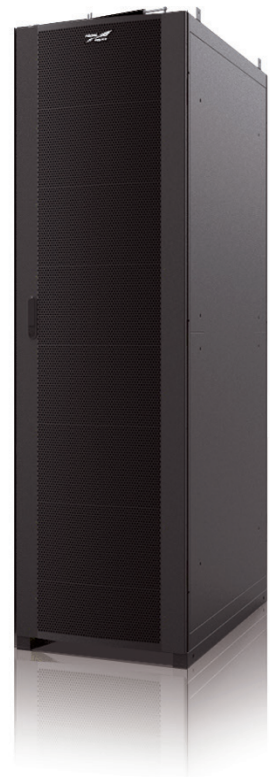

## Micro Modular Data Center

### Solution introduction

Micro modular data center solution chooses a 19-inch rack as its cabinet, integrated by power distribution module, rack type UPS, batteries, power environmental monitoring, cabling management, cooling, etc. It reduces the distance of each part, decreases the failure point number and meets the various of demand from customers.

### Applications



Government



Intelligent Community



Security & bank



Enterprise



Education

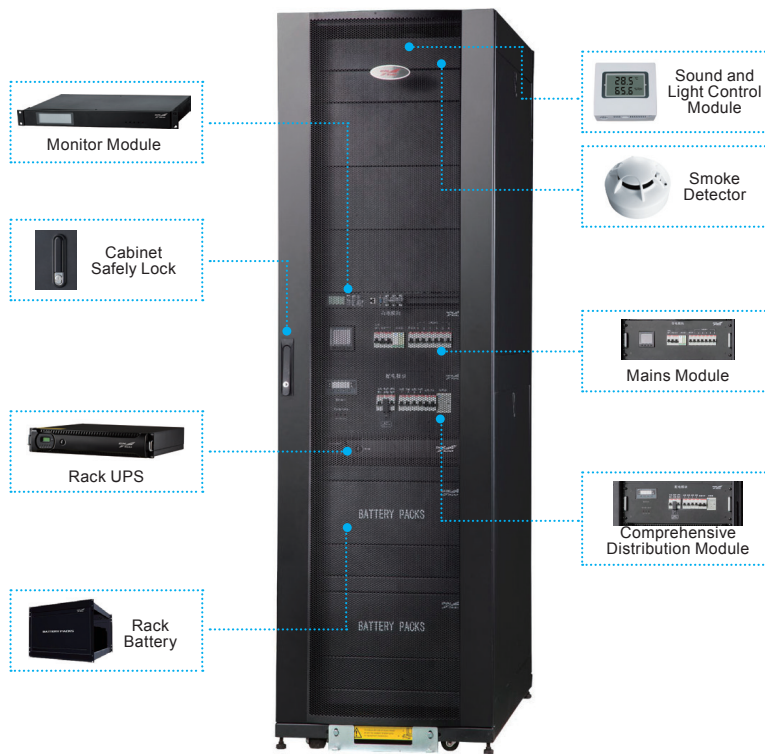

Item	Specification
System(W*D*H)	600*800*2000/600*1000*2000
UPS capacity	1-15KVA
User space	4U-17U
Rated voltage	220Vac/Customized
Rated frequency	50Hz/Customized
IP grade	IP20

## Medium Modular Data Center

### Solution introduction

Medium modular data center adopts full closed design, integrated with power supply and distribution, cooling system, cabinet, fire protection, monitoring module and so on. It can be used to install server, KVM, routers, switches, etc.

### Applications



Government



Enterprise



Security & bank



Healthcare



Manufacturing



Office Building



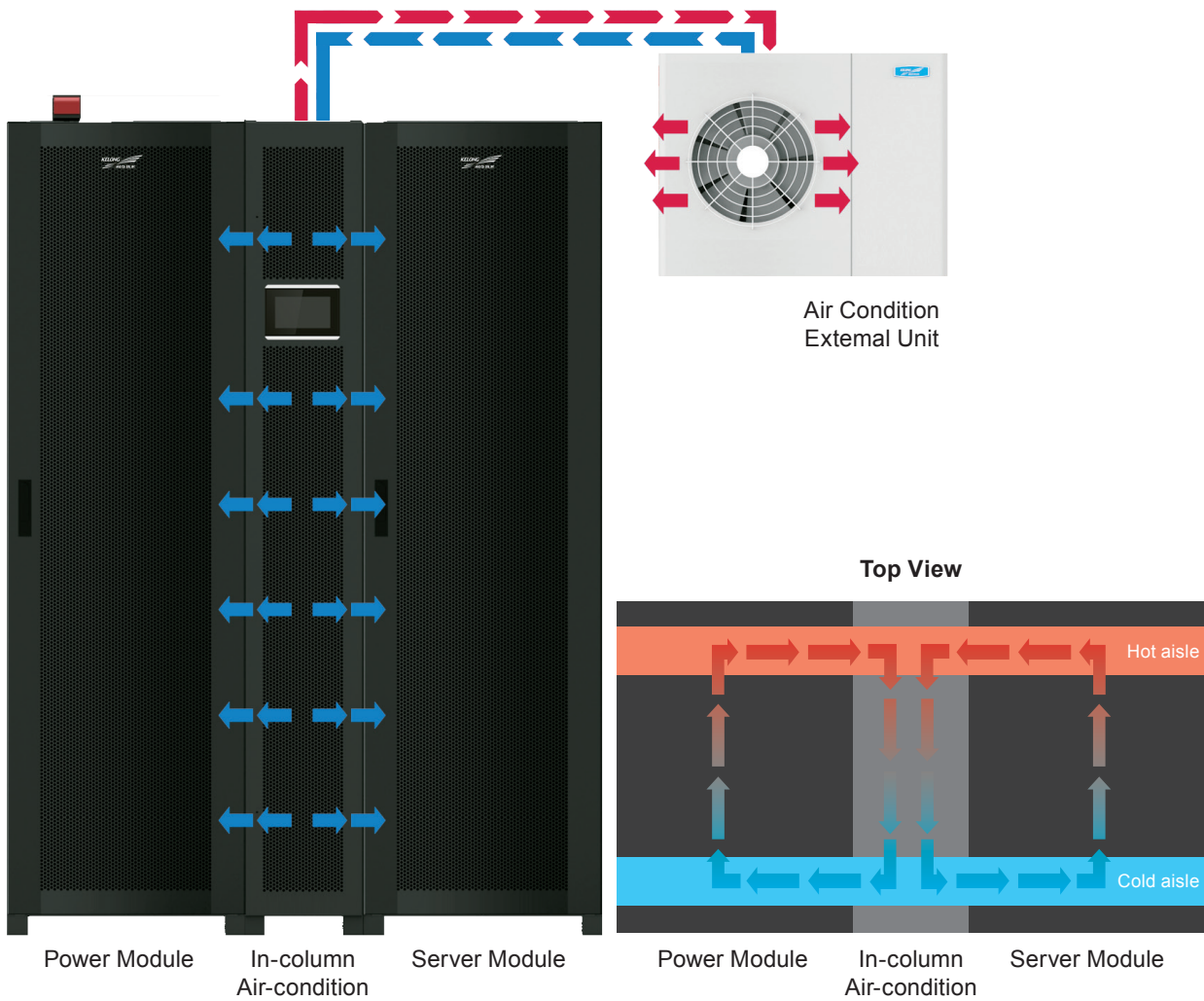

## Medium Modular Data Center

Our solution adopts full closed system refrigeration design, row level in refrigeration system and advanced technology in equipments such as UPS, precision air conditioner and so on. All these make our data center outstanding and the energy saving can be up to more than 30%!



## Technical Parameters

Parameter		Configuration		
				
		KDU02-006-051	KDU03-010-085	KDU04-010-085
System	W*D*H(mm)	1500*1400*2000	2100*1400*2000	2700*1400*2000
	Noise(dB)	<65		
UPS	Power	6kVA/4.8kW	10kVA/8kW	10kVA/8kW 15kVA/12kW
Cabinet	No.	2	3	4
	Space	42U	84U	126U
	Over Temp.	Front and back door will bounce off automatically		
Battery	Backup Time	1h(settable) & internal or external		
Air conditioning	Refrigerating capacity(kW)	5.1	8.5	8.5/12.5
	SHR	100%		
	Circulating air volume	1100CMH	1600CMH	1600CMH
	The heating capacity(kW)	3		
	Refrigerant	R410A		
	Operation Temp.	0~35°C (indoor) -20°C~45°C (outdoor)		
	W*D*H(mm)	300*1400*2000mm		
Monitor	Local display	7inch touch screen,temperature and humidity,smoke detector,door sensor etc.		
	UPS	RS232,RS485		
	Distribution	Electricity meter ,RS485,Intelligent PDU,SNMP protocol		
	Air conditioning	Precision air conditioning or ordinary air conditioning		
	Alarm monitor	Sound and light alarm, water alarm via email alarm, telephone voice alarm;Water immersion, infrared, lightning detection;Battery monitoring		
	Centralized monitoring	centralized network monitoring and room entrance guard system links, IP camera links		
Option	-	ATS,guide rail,layer board		

Note: Maximum 8 cabinets can be added into one system; or multi-system working in parallel for high reliability.

## Large Modular Data Center

### Solution introduction

Large modular data center solution chooses the micro module as one unit, consist of power distribution, cabinet, air conditioning, monitoring, wiring, firefighting and so on. The whole system features with prefabrication in the factory, easy installation on site and fast delivery.

### Applications



Security



Insurance



Bank



Government



Large data center room



Telecom



Manufacturing



#### Power supply and distribution system

Precision column cabinet

High intelligence      High reliability  
High efficiency      Energy Saving



#### UPS

Two part:modular UPS and HV DC power, can be configured as modular system according to the power consumption and the redundancy level requirements.

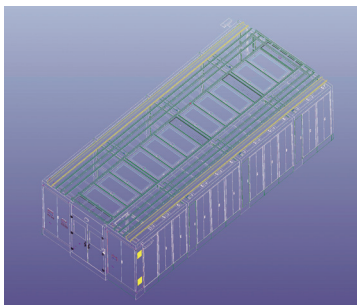

#### Comprehensive wiring

Professional integrated wiring system:power line from the top side, the air conditioning pipe from the bottom, flexible layout of pipe line; reserving the space for walking lines.

Based on advanced and forward-looking idea, the wiring standard strictly carry out the EMC design requirement of separating high and low voltage, fully guarantee the demand of data transmission and the quality of communication.

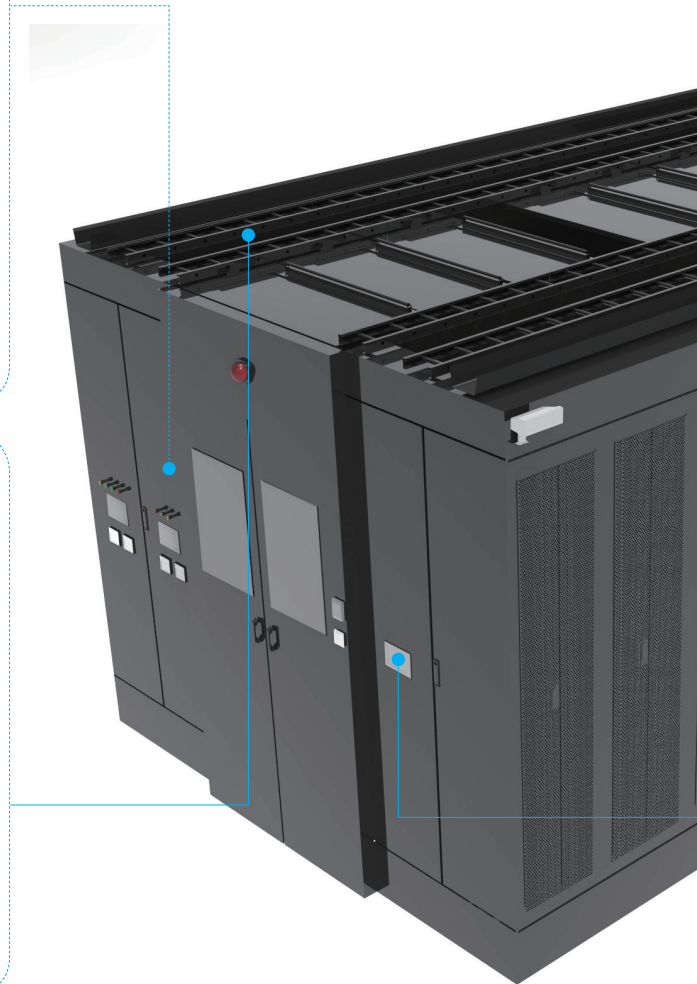

### Cooling system

Two kinds of precision cooling system: air cooling and water cooling system. The closed cold aisle technology and precision air exhaust technology have greatly improved cooling and energy efficiency, as well as reducing energy consumption.



### Rack

With the advantage of rugged, load bearing capacity and impressive appearance



### Cold aisle

Meeting the cooling requirements of the medium heat-density rack; delivering the cooled air to the heat radiation equipment.

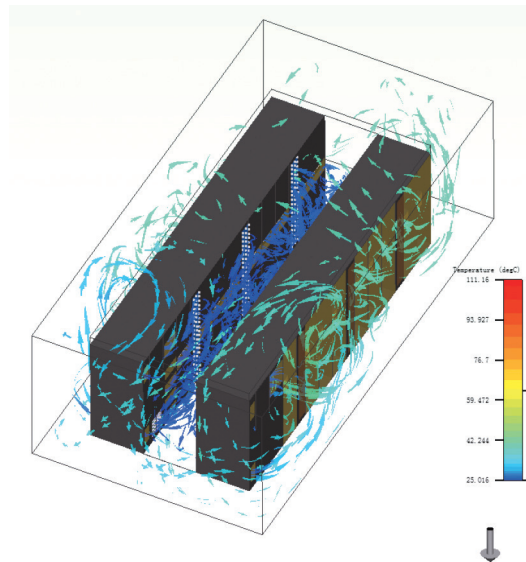

### Monitor system

Daily operation and management of the monitoring system ensure the smooth operation of the system, user-friendly and easy maintenance.



## Successful Applications



Gansu Bank of Communications - More than 60 sets of Micro Modular Data Center



Xinjiang Local Taxation Bureau - 120 sets of Micro Modular Data Center





Beijing HuiLongGuan Middle School - 1 set of Medium Modular Data Center



Gansu Construction Bank Information Construction - 1 set of Medium Modular Data Center

## Successful Applications



Beijing Kehua Zhongsheng Cloud Computing Data Center - Large Modular Data Center (the total construction area is 70,000 square meters)



Guangdong Development Bank Chongqing Branch - Large Modular Data Center

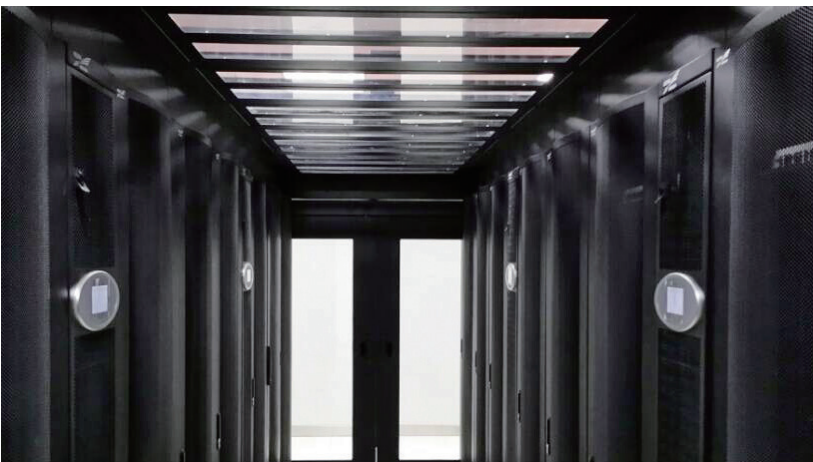

Commercial Aircraft Corporation of China, Ltd. (COMAC) - Large Modular Data Center





**Xiamen Kehua Hengsheng Co., Ltd.**

Add: No.457, Malong Road, Torch High-Tech Industrial Zone, Xiamen Fujian China

Tel: +86 592 5160516

Fax: +86 592 5162166

[www.kehua.com](http://www.kehua.com)

Version No.: 20160525-01-500

**Copyright © Xiamen Kehua Hengsheng Co., Ltd 2016. All rights reserved.**

No part of this document may be reproduced or transmitted in any form or by any means without prior written consent of Kehua Hengsheng Co., Ltd.

**General Disclaimer**

The information in this document may contain predictive statements including, without limitation, statements regarding the future financial and operating results, future product portfolio, new technology, etc. There are a number of factors that could cause actual results and developments to differ materially from those expressed or implied in the predictive statements. Therefore, such information is provided for reference purpose only and constitutes neither an offer or an acceptance. Kehua may change the information at any time without notice.